



Improving your PERFORMANCE

621F/RE fixed speed close coupled pump

Technical information and features

- Flow rates from 2.85 litre/min to 18.1 litre/min, pressures up to 4 bar (60psi)
- Fixed speed, compact design
- Rugged IP55 AC motor for industrial environments
- All pumpheads have tool unlocking with safety interlock option
- 620RE twin-roller pumphead with CIP/SIP rotor
- Rapid snap-fit tube loading, 620RE pumphead accepts both 12mm and 17mm industrial and sanitary LoadSure™ elements
- Two years comprehensive warranty



621F/RE (litre/min)

LoadSure™ element material	Speed range (rpm)	LoadSure™ 12mm	LoadSure™ 17mm
Marprene TM, Bioprene TM	77 / 251	2.85 / 9.29	4.54 / 14.8
Marprene TL, Bioprene TL	77 / 251	2.85 / 9.29	5.18 / 16.9
Silicone	77 / 251	2.98 / 9.71	4.69 / 15.3
Neoprene, STA-PURE	77 / 251	3.06 / 9.99	5.56 / 18.1

Note: 621F drive can also be fitted with the 625L high accuracy low pulse pumphead.

Tube life for 620RE and 620R two roller pumpheads with water @ 20C 100rpm rotor speed

Bioprene TL / Marprene TL	6000
STA-PURE	6000
Neoprene	430
Silicone	230
Butyl	100
Tygon	90
Fluorel	70

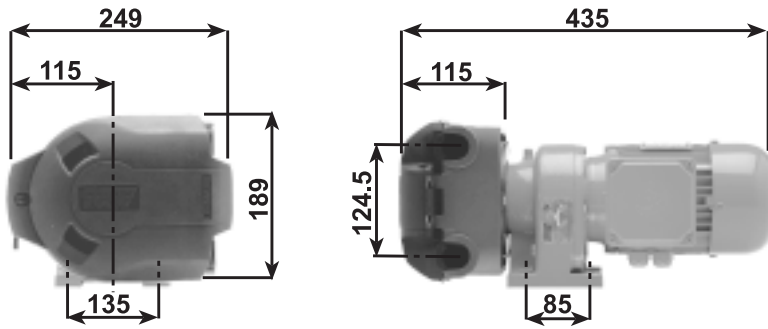

621F/RE fixed speed close coupled pump

Product codes		
621F/RE 77 rpm 251 rpm	Drive + two roller pumphead for LoadSure™ elements	060.8122.E20 060.8152.E20
620RE 620RE4 620R	Pumphead Pumphead Pumphead	063.0231.000 063.0431.000 063.0211.000

LoadSure™ tube element codes for 620RE and 620RE4 pumpheads						
	12mm DIN 15	12mm Tri-clamp 3/4"	17mm DIN 15	17mm Tri-clamp 3/4"	12mm Cam and Groove 3/4"	17mm Cam and Groove 3/4"
STA-PURE	960.0120.PFD	960.0120.PFT	960.0170.PFD	960.0170.PFT	-	-
Bioprene TM	903.M120.PFD	903.M120.PFT	903.M170.PFD	903.M170.PFT	-	-
Bioprene TL	903.0120.PFD	903.0120.PFT	903.0170.PFD	903.0170.PFT	-	-
Plat. Silicone	913.0120.PFD	913.0120.PFT	913.0170.PFD	913.0170.PFT	-	-
Marprene TM	-	-	-	-	902.M120.PPC	902.M170.PPC
Marprene TL	-	-	-	-	902.0120.PPC	902.0170.PPC
Per. Silicone	-	-	-	-	910.0120.PPC	910.0170.PPC
Neoprene	-	-	-	-	920.0120.PPC	920.0170.PPC

Specification

Weight	621F/RE: 18.5kg
Operational temperature range	5°C to 40°C
Noise	Max <75dBA at 1m
Standards	CE, BS0800, IEC335-1, EN60529 (IP55)
Supply	230/400V 3ph 50/60Hz

Materials of construction

Drive:	Aluminium
Motor	Cast iron
Gearbox	Cast iron

620RE, 620RE4, 620R pumpheads

Track	Aluminium LM24M powder coated
Guard	Outer layer - Polyurethane PBA Inner shell - Grilamid TR55
Guard catch	EN34 case hardened Xlan 5200 coated

Rotor:	Fortron 1140L4 (PPS)
Hub and roller arms	Dupont Hytrel G5544
Cover	Stainless steel 304
Main rollers	Carbon steel
Main roller bearings	Nylatron
Guide rollers	Polypropylene
Tube clamp sets	



Watson-Marlow-Bredel Pumps
Falmouth
Cornwall
England
TR11 4RU
Tel: +44 (0) 1326 370370
Fax: +44 (0) 1326 376009
www.watson-marlow.com
Email support4gb@watson-marlow.co.uk