

720SN, 720UN, 720US, 720DuN, and 720DuS with 720R and 720RX pumpheads

700 series

Watson-Marlow Bredel

COMMON FEATURES AND BENEFITS

- Flows up to 8.8 GPM and 30 psi maximum operating pressure with single channel 720R pumphead
- Continuous tubing from source to delivery
- 3,600:1 control ratio (0.1 to 360rpm speed range)
- Display pumphead speed or calibrated flow rate
- Manual control flow calibration and MemoDose for single shot dispensing
- Maintenance-free brushless DC motor
- Dual voltage 100-120/200-240V 50/60Hz power supply range, 350VA
- Optional integral float switch leak detector and fluid management
- 720RX extension pumphead can be fitted to double the flow

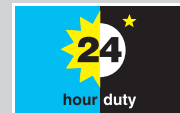

Watson-Marlow Bredel ... Value for life

TECHNICAL DATA

Functionality	720SN	720UN	720DuN	720US	720DuS
Enclosure - ingress protection rating	NEMA 4X	NEMA 4X	NEMA 4X	NEMA 4X	NEMA 4X
Manual control					
Keypad speed control with simple calibration to display flow	•	•	•	•	•
Comprehensive calibration for flow rate display; metric or imperial units			•		•
Numeric keypad for entry of speed, flow or PIN code			•		•
Cumulative volume indication			•		•
Remote control					
Run/stop, direction change, auto/manual mode, leak detector input (via contact closure or 5V TTL to 24V industrial logic)		•	•	110VAC	110VAC
Remote operation of MemoDose (foot/hand-switch or logic input)		•	•	110VAC	110VAC
Four programmable digital status outputs through 24V, 30W relays		•	•	110VAC	110VAC
Analog speed control					
Software programmable inputs; 0-10V, 1-5V or 4-20mA		•	•	•	•
Analog outputs; 0-10V (8 bit resolution)		•		•	
Analog outputs; 0-10V, 4-20mA (8 bit resolution)			•		•
Keypad/analog input scaling (replacement of diaphragm pumps)			•		•
Frequency output; 0-768Hz			•		
RS485 digital communication			•		•
Digital network serial control					
Security					
Basic security code to protect set-up		•		•	
Dual operator/supervisor PIN code protection of pump settings			•		•

PERFORMANCE

		Tube bore and flow rates (GPM)				
	Speed rpm	9.6mm	12.7mm	15.9mm	19.0mm	25.4mm
720R	0.1-360	0.0005-1.8	0.001-3.5	0.001-4.8	0.002-6.6	0.003-8.8
720R/RX	0.1-360	0.001-3.6	0.002-7.0	0.002-9.6	0.004-13.2	0.006-17.6

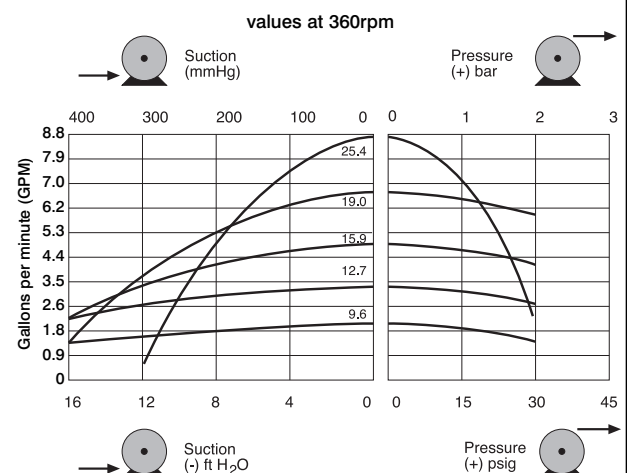

TECHNICAL DRAWINGS

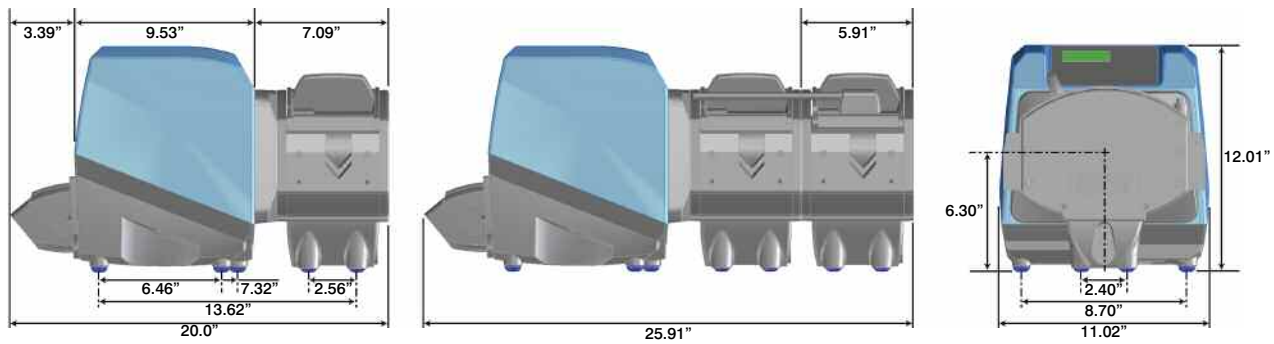

TECHNICAL SPECIFICATION

	720SN, 720UN, 720US, 720DuN, 720DuS
Ingress rating	NEMA 4X
Enclosure	Watertight, dustproof
Suitability	Corrosion resistant for heavy industrial environments
Humidity	Condensing 10-100% RH
Temperature	40F to 104F (5C to 40C)
Pump weight	55lb with 720R, 69lb with 720RX
Control ratio	3,600:1
Torque rating	Max 2.5Nm (shaft, x 4 at pumphead)
Noise	< 85dB(A) at 1m
Standard	CE, cETLus
Power supply	100-120V/200-240V 1ph 50/60Hz, 350VA

MATERIALS OF CONSTRUCTION

Component	Material
Keypad	Polyester
Switch-plate	ABS PA-765
Rear blanking plate	Stainless steel 316
Drive casework	Pressure die-cast aluminum (top - LM6, base - LM24)
Casework and pumphead coating	Alocrom pre-treatment, exterior grade polyester powder coat
Drive shaft	Stainless steel 440C
Pumphead body/track	Aluminum
Rotor end plates	Aluminum
Rollers	MOS2 filled nylon 6 (Nylatron)
Springs/spindles	Stainless steel

ORDER INFORMATION

Pump and pumphead product codes			
Description	Partcode	Description	Partcode
720SN/R	070.413N.00A	720R pumphead only	073.2001.000
720SN/R/RX	070.413N.X0A	720RX pumphead only	073.2011.000
720UN/R	070.414N.00A		
720UN/R/RX	070.414N.X0A		
720DuN/R	070.415N.00A		
720DuN/R/RX	070.415N.X0A		
720US/R	070.414S.00A		
720US/R/RX	070.414S.X0A		
720DuS/R	070.415S.00A		
720DuS/R/RX	070.415S.X0A	Leak detector	079.6131.000

Continuous tubing for 720R and 720RX					
	9.6mm	12.7mm	15.9mm	19mm	25.4mm
Sta-Pure	960.0096.048	960.0127.048	960.0159.048	960.0190.048	960.0254.048
Bioprene	903.0096.048	903.0127.048	903.0159.048	903.0190.048	903.0254.048
Marprene	902.0096.048	902.0127.048	902.0159.048	902.0190.048	902.0254.048
Pumpsil	913.A096.048	913.A127.048	913.A159.048	913.A190.048	913.0254.048
Neoprene	920.0096.048	920.0127.048	920.0159.048	920.0190.048	920.0254.048

All flow rates shown were obtained pumping water at 20C (68F) with zero suction and delivery heads. Watson-Marlow, Loadsure, Bioprene and Marprene are trademarks of Watson-Marlow Limited. Disclaimer: The information contained in this document is believed to be correct but Watson-Marlow Limited accepts no liability for any errors it contains, and reserves the right to alter specifications without notice. © Chem-Sure and © STA-PURE is a registered trademark of W.L. Gore & Associates Inc. Please state the product code when ordering pumps and tubing.



Watson-Marlow Breidel Pumps
 37 Upton Drive
 Wilmington, MA 01887
 Tel: 800 282 8823 Fax: 978 658 0041
 www.watson-marlow.com support@watson-marlow.com
 Watson-Marlow Breidel ... Value for life