

Operating Instructions



Drum Pumps Type

F 424 ... sealless

F 425 ... liquid saver

F 426 ... mixing pump

*F 430 ... mechanical
seal*

Possible Motor - Pump Combinations



- Only use motors and pumps in the following combinations.

①

Do not operate motor in hazardous locations.
Do not use the pump for transferring flammable liquids.

②

For use in hazardous locations only use explosion-proof electric motors which are approved for ZONE 1 or compressed air motors.
For transferring flammable liquids only use pumps which are approved for ZONE 0.

③

For use in hazardous locations only use explosion-proof electric motors which are approved for ZONE 1 or compressed air motors.
Do not use the pump for transferring flammable liquids.

**Motors
not explosion-proof**

Pumps

**Motors
explosion-proof**

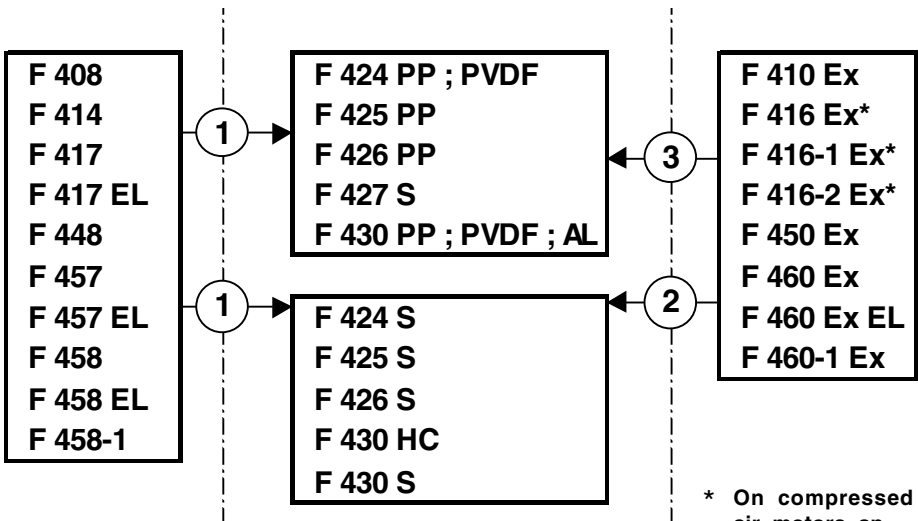

* On compressed air motors an approval for ZONE 1 is not necessary.

For use in hazardous locations



- For transferring flammable liquids class AI, All and B only use pumps which are approved for ZONE 0.

F 424 S-../.. EC-Type-Examination Certificate
PTB 00 ATEX 4108 X

F 425 S-../.. EC-Type-Examination Certificate
PTB 99 ATEX 4001 X

F 426 S-../.. EC-Type-Examination Certificate
PTB 00 ATEX 4109 X

F 430 S-../.. EC-Type-Examination Certificate
F 430 HC-../.. PTB 00 ATEX 4110 X

- Only use explosion-proof electric motors which are approved for ZONE 1 or compressed air motors.

F 410 Ex Commutator Motor

F 416 Ex Compressed Air Motor (approval not necessary)

F 416-1 Ex Compressed Air Motor (approval not necessary)

F 416-2 Ex Compressed Air Motor (approval not necessary)

F 450 Ex Commutator Motor

F 460 Ex Commutator Motor

F 460 Ex EL Commutator Motor

F 460-1 Ex Commutator Motor



- Observe EC-Type-Examination Certificate.
- The pump is not approved for stationary installation.
- The explosion-proof motor must definitely be outside the barrel and/or container.



- Only use electrically conductive hoses (see TRbF 131 part 2).



- The installation and operation must comply with the relevant Health & Safety Regulations.

Before starting operation in hazardous locations

Connect the earth continuity conductors (earth wires) to the designated screw on the explosion-proof motor and pump. If the connection between motor and pump already provides a conductive path, one of the earth continuity conductors may be deleted.

Connection to the mains via an explosion-proof plug device or an explosion-proof cable terminal box only.

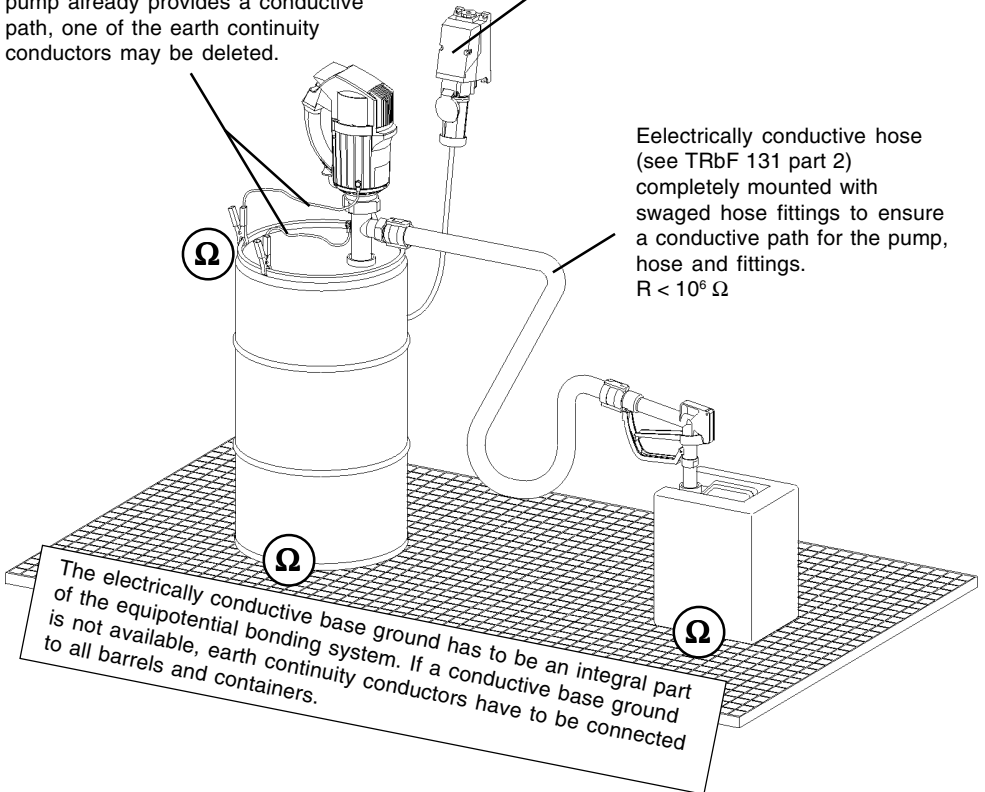

Electrically conductive hose (see TRbF 131 part 2) completely mounted with swaged hose fittings to ensure a conductive path for the pump, hose and fittings.
 $R < 10^6 \Omega$

Ω Remove paint and dirt from all connection points of earth continuity conductors and containers to the electrically conductive base ground to ensure good conductivity.



The use of the commutator motor in combination with the pump requires a complete and definite equipotential bonding. An equipotential bonding consists in an electrically conductive connection between the motor and the pump according to EN 50 014:1994-03 Paragraph 15 and DIN VDE 0165:1991-02 Paragraph 5.3.3.

The pump has to be arranged in a way that no friction and impinge sparks form and that the operating conditions ensure safe operation.

Safety Instructions

- Only use the pump for its intended purpose.
- Never leave the pump unattended.
- The pump has to be used in vertical position only.
- When pumping liquids which contain solid particles in suspension, a suction strainer must be used.
- Install the pump in a way which ensures that it cannot fall into the container.
- Only use the pump with a suitable hose.
- Ensure that the hose is securely fixed to the hosetail.
- Regularly check motor, pump, hose and connections to ensure safe operation.
- The pump should not be immersed deeper into the liquid than the outlet connection.



- Comply with all relevant safety instructions.
Wear appropriate protective clothing.
(Face shield, protective gloves, etc.).

- Comply with the operating instructions of the motor.
- Never operate the pump dry.
- The pump should not be exposed to the weather.
- Before removing the motor from the pump:
Completely drain pump, flexible hose and hand tap.
- Clean after each operation.
- Never store the motor in areas in which corrosive vapours exist.
- Before inserting the electrical plug into the socket or connecting the air supply hose to the air motor, ensure that the Start/Stop switch is set to "0" (Stop).

Starting Operation

Available drive motors :

- **Commutator motors** *F 408, F 410 Ex, F 417, F 417 EL, F 448, F 450 Ex, F 457, F 457 EL, F 458, F 458 EL, F 458-1, F 460 Ex, F 460 Ex EL, F 460-1 Ex.*
- **Compressed air motors** *F 416 Ex, F 416-1 Ex, F 416-2 Ex*

- Make sure that the supply voltage corresponds to the voltage indicated on the name plate. When using air motors, please do not exceed the maximum operating pressure and always use a filter-regulator-lubricator unit.
- Put the motor onto the pumps.



- Never operate the pump unless the union nut between pump and motor has been firmly tightened by hand.
- Immerse the pump into the liquid and secure it in a vertical position by the use of a compression gland or a container clip.
- Always check the power supply cable for damage before starting operation.
- Keep solvents away from the power supply cable.
- Before inserting the electrical plug into the socket or connecting the air supply hose to the air motor, ensure that the Start/Stop switch is set to "0" (Stop).
- Insert the plug or connect the air supply hose.
- Switch on the motor.
- On motors F 417 EL, F 458 EL and F 460 Ex EL the speed may be regulated by the adjustment knob (control of delivery rate).

Air Motor F 416 Ex, F416-1 Ex



- Before connecting the air supply hose to the motor, set the Start/Stop switch to "0" (Stop).
(On model F 416 Ex unlock locking mechanism of the on/off operating trigger).

- Use a silencer or an exhaust air hose.
- Air consumption F 416 Ex, F 416-1 Ex, F 416-2 Ex :
At 3 bar operating pressure ~ 7 l/sec.
At 6 bar operating pressure ~14 l/sec.

Liquid saver pump

F 425 S-41/34, F 425 PP-50/34

As soon as no liquid will be delivered anymore :

- Close the flow back stop valve while the motor is still running.
- Switch off the motor.

To achieve an utmost barrel emptying :

- Tilt the barrel.

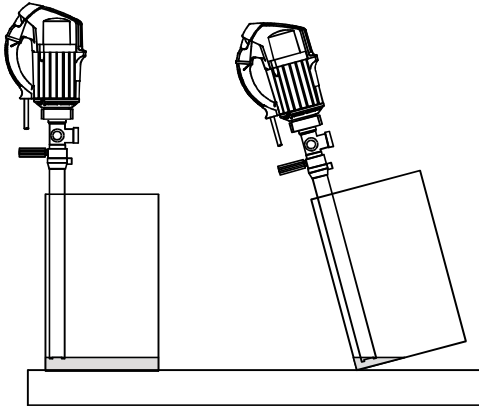

- Always completely drain pump before storing.

Valve OPEN

Valve CLOSED

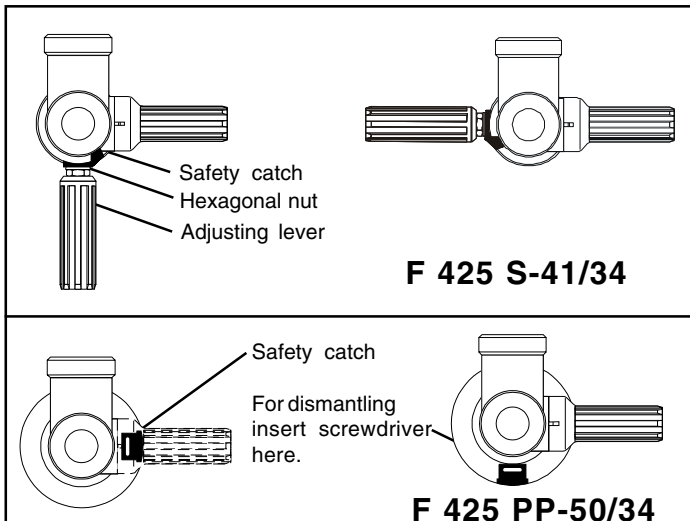

Mixing Pump

F 426 S-41/38, F 426 PP-50/33



- When mixing electrically non-conductive liquids there is a risk that the circulated liquid will be charged electrostatically. Make sure that any ignition risk will be eliminated.



- When, during pumping and mixing operations, the mixing openings are above the liquid level, there is a risk of splash. On open barrels and containers splash guards must be installed.

mixing

pumping

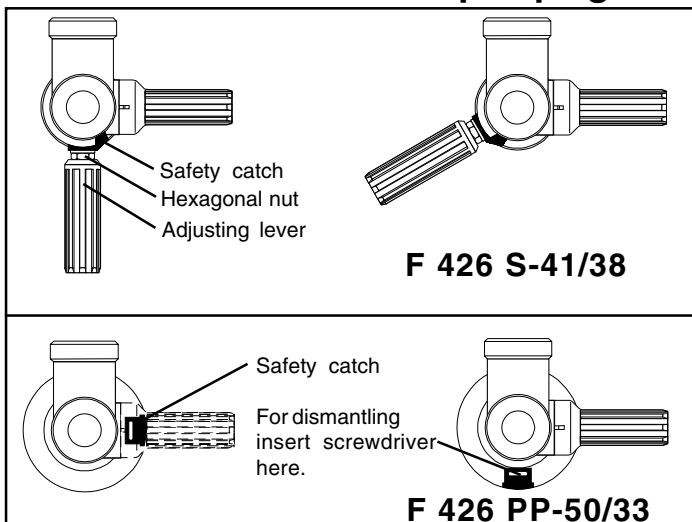

Picture 2

Cleaning after each operation

Clean the pump by flushing a appropriate cleaning agent.

- The pump should not be immersed into the cleaning agent higher than the outlet connection.
 - Pump and hose must be compatible with the cleaning agent.
 - Do not use flammable liquids to clean the pump or motor.
 - Do not separate the motor from the pump as long as there is still any backpressure within the system.
- First drain pump and discharge hose.

Dismantling of Pumps for Cleaning

- 1 ● Unplug the pump or disconnect the air supply hose.
- 2 ● Unscrew the union nut between pump and motor.
- 3 ● Remove motor from the pump.
- 4 ● Never store the motor in areas in which corrosive vapours exist.
- 5 ● Dismantling of pump as follows :

***5.1 F 424 S-43/38, F 424 S-43/37 Z,
F 424 S-50/45 Z, F 424 PP-41/36,
F 424 PVDF-41/36, F 424 PP-41/35 Z
F 424 PVDF-41/35 Z, F 424 PP-50/43 Z***

- Unscrew foot piece.
- Lock coupling on the motorside of the pump by a wrench or a big screwdriver and unscrew the impellor.
- Take the inner tube out of the pump assembly.

5.2 F 424 PP-50/38, F 424 PVDF-50/38

- Unscrew foot piece.
- Lock coupling on the motorside of the pump by a wrench or a big screwdriver and unscrew the impellor.
- Unscrew the outer tube.

5.3 F 425 S-41/34, F 425 PP-50/34, F 426 S-41/38

- On F 425 S and F 426 S:
Release adjusting lever and hexagonal nut.
Take off safety catch (see pictures on page 8 and 9).
- On F 425 PP: Press out safety catch with a screwdriver (see page 8, picture 1).
- Set outer tube to position:
F 425 ... to position "Valve OPEN"
F 426 ... to position "mixing"
- Take the inner tube out of the pump assembly.

5.4 F 426 PP-50/33

- Remove threaded pin.
- Take out inner tube.
- Press out safety catch with a screwdriver.
- Set outer tube to position:
"mixing"
- Take out the inner tube of the mixing tube (see page 9, picture 2).

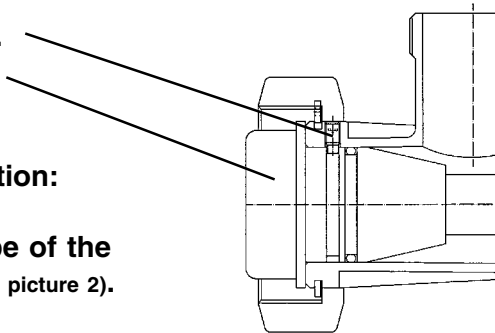

5.5 F 430 ...

- Take the inner tube out of the pump assembly.



FLUX PUMPS CORPORATION

4330 Commerce Circle
Atlanta, Georgia 30336
phone: 404-691-6010
fax: 404-691-6314
toll free: 800-FOR-FLUX
www.flux-pumps.com