



SPX65 High-Pressure Hose Pumps

Features and Benefits

- High-strength, twin-bearing hub integrated into the pumphead
- Rotor always fully and centrally supported by its own bearings
- Fail-safe shaft design
- New flat shim and improved epoxy shoe design
- Faster hose changing and improved sealing
- Easy access to shims and shoes
- Unique buffer zone provides protective barrier between pumphead and gearing
- Patented direct-coupled design
- Ultra compact planetary gearing
- No drive alignment for faster set-up
- No coupling or baseplate for compact footprint
- Adapter available for fitting hydraulic or pneumatic motors
- Improved frame design
- Increased corrosion resistance
- Compact design, low maintenance,
- Two year warranty

Performance Chart

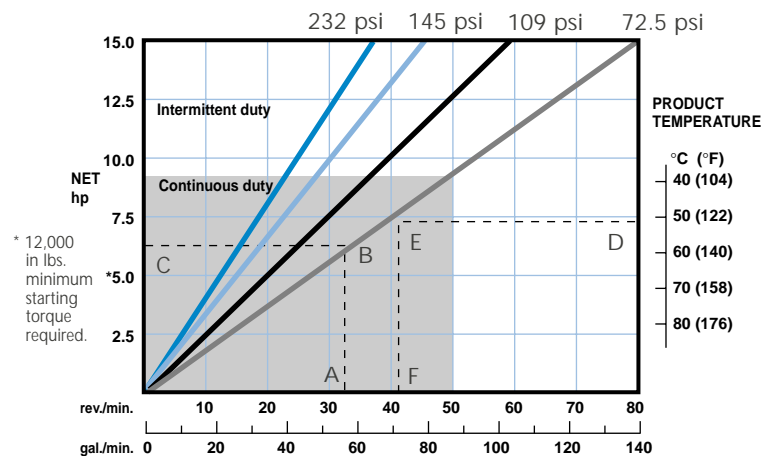

How to calculate speed/horsepower

- A Flow required, indicates pump speed
- B Calculated discharge pressure
- C Horsepower required
- D Fluid temperature
- E Calculated discharge pressure
- F Maximum recommended pump speed**

** For maximum hose life, speed point (A) should be lower than temperature adjusted speed point (F). See example points (A) thru (F).

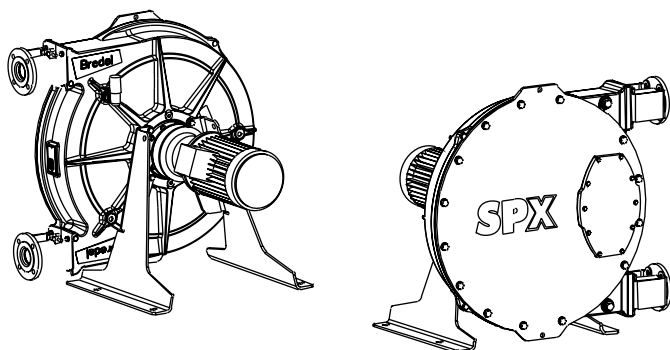
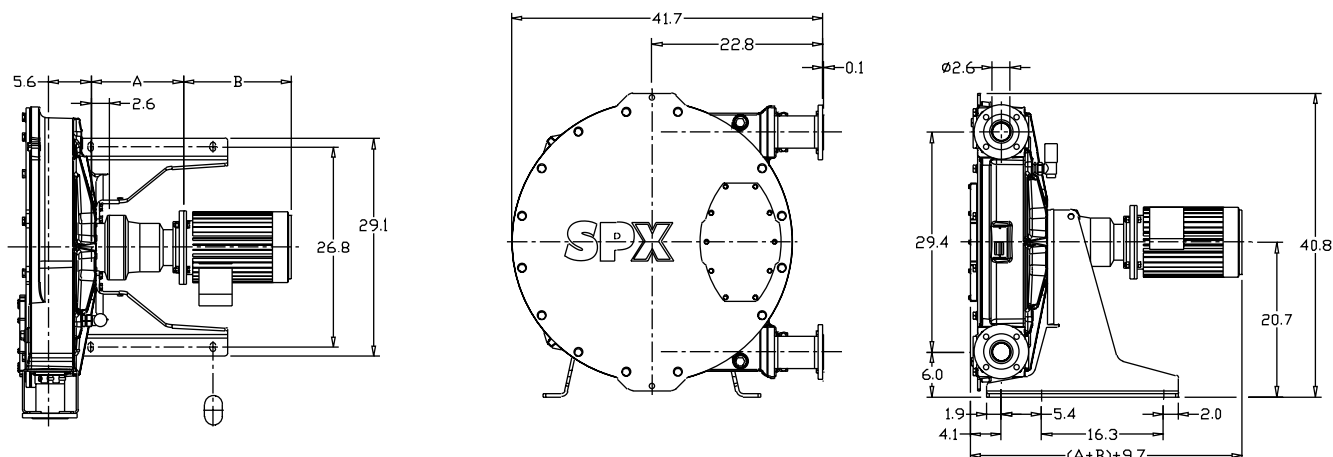

NOTES:

1. ALL DIMENSION ARE FOR REFERENCE ONLY.
2. WHEN INSTALLING, ALLOW 69-92" LINEAR CLEARANCE TO FLANGE FOR HOSE CHANGING

GEAR REDUCER	INPUT FRAME	A	WT. LBS.	MOTOR P/N	B	FRAME	HP	ENCLOSURE	WT. LBS.
GR02030	180TC	11.7	74	P18G3882	14.5	182TC	3.0	TEFC-EM	110
	210TC	11.7	73	P18G1132	14.5	182TC	3.0	TEFC-XE	118
	210TC	14.5	87	P18G3888	14.5	182TC	3.0	TEFC-EMT	110
GR13030	180TC	13.2	84	P18G1123	14.5	182TC	3.0	TEFC-XEX	125
	210TC	13.2	83	P14X3049	13.8	145TC	3.0	FCEZ-EM+	50
	210TC	16.0	97	P18G2521	15.3	182TC	3.0	FCXP	82
GR13045	210TC	17.0	140	P18G3883	14.5	184TC	5.0	TEFC-EM	120
	250TC	17.0	139	P18G1133	14.5	184TC	5.0	TEFC-XE	118
	250TC	19.8	153	P18G3889	14.5	184TC	5.0	TEFC-EMT	120
GR04045	180TC	15.8	150	P18G1124	14.5	184TC	5.0	TEFC-XEX	125
	210TC	15.8	149	P18G3864	13.8	184TC	5.0	FCEZ-EM+	135
	250TC	18.6	163	P18G1051	15.3	184TC	5.0	FCXP	125
GR13065	180TC	17.4	204	P21G3882	17.0	213TC	7.5	TEFC-EM	170
	210TC	17.4	203	P21G1101	17.0	213TC	7.5	TEFC-XE	180
	250TC	20.1	217	P21G3888	17.1	213TC	7.5	TEFC-EMT	170
GR04065	180TC	18.9	207	P21G1091	17.1	213TC	7.5	TEFC-XEX	185
	210TC	18.9	206	P21G3863	16.9	215TC	7.5	FCEZ-EM+	185
	250TC	21.7	221	P21G1034	17.8	213TC	7.5	FCXP	154
SPX65 Pumphead			860	P21G3883	17.0	215TC	10	TEFC-EM	185
				P21G1102	17.0	215TC	10	TEFC-XE	180
				P21G3889	17.1	215TC	10	TEFC-EMT	185
				P21G1092	17.1	215TC	10	TEFC-XEX	185
				P21G3864	16.9	215TC	10	FCEZ-EM+	190
				P21G1139	17.8	215TC	10	FCXP-EM	154

Note: Dimensions shown are based on the standard pump and motor configuration. Overall length may vary depending on actual motor selection.

SPX65 High-Pressure Hose Pumps

Technical Specifications

- Displacement: 1.77 gal/rev
- Supply: 230/460 or 575 three phase
- Operating Speeds: Up to 50 rpm continuous
Up to 90 rpm intermittent
- Fluid Temperature Range: -4° to 175°F
- Hose Lubricant Required: 5.3 gallons
- Flow Range: Up to 124 gpm
- Discharge Pressure: Up to 232 psi
- Suction pressure: 28 ft. lift to 30 psi
- Available Hose Materials: Natural Rubber, BUNA N, BUNA K, EPDM, Hypalon (pending)
- Available Insert Materials: Polypropylene, 316 SS, PVDF, PVC
- Fittings: 2.5" 150# Flange

Materials of Construction

- Pumphead: Cast iron
- Rotor: Cast iron
- Cover: Mild steel
- Hub: Cast iron
- Shoes: Epoxy
- Flanges and Flange Brackets: Galvanized steel or 304 SS
- Frame: Galvanized steel
- Hardware: Zinc plated steel or 304 SS
- Shaft: Alloy steel
- Shims: 316 SS
- Seals: NBR

The information contained in this document is believed to be correct, but Watson-Marlow/Bredel Pumps accepts no liability for any errors it contains, and reserves the right to alter specifications without notice.

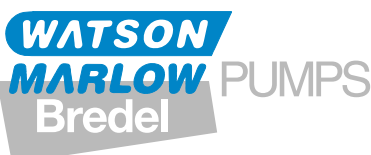

Watson-Marlow, Inc.

37 UPTON TECHNOLOGY PARK, WILMINGTON, MA 01887-1018
TEL: 800-282-8823, 978-658-6168 / FAX: 978-658-0041
<http://www.watson-marlow.com>