

E - SERIES GEARBOX LUBRICATION

C1.1 E-SERIES WORM GEAR GEARBOXES: See data sheet and/or assembly drawing at the front of this manual to find the case size of gearbox supplied. See table C1.3 for cross reference.

C1.2 Models E05 through E55 (without optional drywell). Your gearbox has been lubricated at the factory with the proper type and amount of lubrication for an ambient temperature range of 51° - 110°F; for different ambient conditions, change to appropriate oil shown in Table C.2.1

Check that the oil level is to the proper level before start-up (see Figure C1.1), and that none was lost during shipment/installation. Replenish if necessary. To prevent leakage during handling the gearbox vent has been replaced with a temporary plug for shipment.

WARNING: VENT MUST BE REINSTALLED PRIOR TO START-UP OR DAMAGE TO GEARBOX WILL OCCUR.

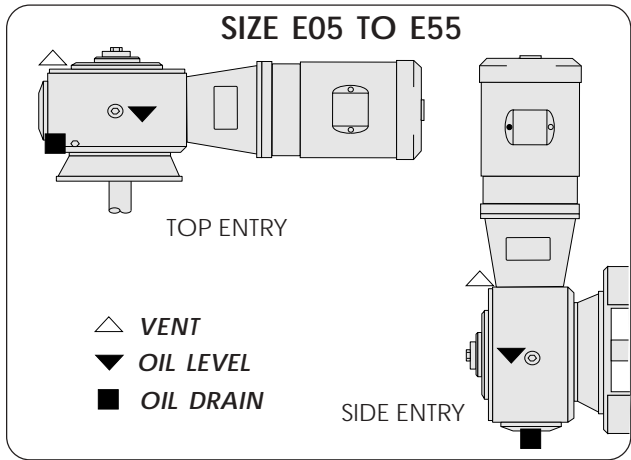

FIGURE C1.1

C1.3 MODELS E6 THROUGH E9 (SHIPPED WITHOUT OIL). See table C1.3 for oil quantities and table C2.1 for the appropriate types of oil. Oil levels shown are approximate and all top entry units should be filled to the levels marked on the dipstick provided before start-up. Note the dipstick on these units is also the vent.

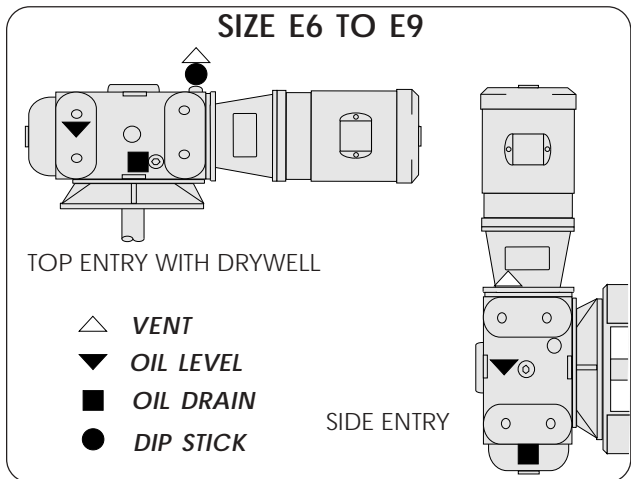

FIGURE C1.2

CAUTION: CONFIRM PROPER OIL LEVEL BEFORE START-UP. USE WORM GEAR (CYLINDER) OILS ONLY. STANDARD GEAR OILS OR OIL WITH EP ADDITIVES WILL CAUSE PREMATURE FAILURE!

C1.4 The lubricant needs to be changed under normal conditions after 150 hours of service. Subsequently, change the oil every 2,500 hours or 6 months, whichever occurs first. Under extreme conditions it is recommended that the lubricant in the gearbox be changed more frequently. Refer to the worm gear chart for the lubricant recommended for temperatures in your area (see Table C2.1). Drain oil when gearbox is still warm. Remove vent to facilitate draining. The oil quantities shown in Table C1.3 are approximate. The exact quantity will be determined when filled to the oil level position on your gearbox. When changing to a different lubricant, clean and flush the gearbox with a light flushing oil before refilling.

Regrease grease lubricated bearings once a month with two shots of grease (when zirc fittings are present).

RECOMMENDED E-SERIES LUBRICATION VOLUMES (PINTS)

SIZE	CASE SIZE	SIDE ENTRY	TOP ENTRY STANDARD	TOP ENTRY W/ DRYWELL
E05	917CDSF	0.5	0.5	N/A
E1	920CDSF	0.5	0.5	N/A
E2	924CDSF	0.9	0.9	N/A
E3	926CDSF	1.2	1.2	N/A
E4	930CDSF	1.6	1.6	N/A
E5	935CDSF	2.1	2.1	N/A
E55	943CDSF	2.8	2.8	N/A
E6	A1002*	§	N/A	1.8
E7	A1252*	§	N/A	3.8
E8	A1602*	§	N/A	6.8
E9	A2002*	§	N/A	10.4

§ Consult factory

TABLE C1.3

***CAUTION: WHEN DRYWELL OPTION IS INCLUDED ON LARGER GEARBOX MODELS, THE EQUIPMENT WILL SHIP DRY (WITHOUT LUBRICANT) FROM THE FACTORY. GEARBOX MUST BE FILLED TO THE PROPER LEVEL WITH THE CORRECT TYPE OF LUBRICANT PRIOR TO START-UP. DO NOT OVERFILL GEARBOX AS EXCESS MAY CAUSE OVERHEATING.**

NOTE: OIL CAPACITIES SHOWN ON TOP ENTRY CHART ARE FOR VERTICAL MOUNTING ONLY. ANGLE MOUNTING REQUIRES LESS LUBRICANT (CONTACT FACTORY FOR VOLUMES)

GEARBOX MAINTENANCE

CAUTION: ANY DISSASSEMBLY OF THE GEARBOX MUST BE PRE-AUTHORIZED BY SHARPE MIXERS WHEN WITHIN WARRANTY PERIOD.

C2.1 If disassembling gearbox, contact factory for complete instructions.

C2.2 Gearboxes can generate temperatures up to 200°F depending on the application and the ambient temperature. When oil temperature exceeds this, refer to the troubleshooting guide in Section B of this manual. Viton lip seals can be substituted to handle higher temperatures.

C2.3 When installing a new lip seal, cover the shaft keyway with smooth tape to protect the seal from damage during installation.

C2.4 Use a sealant between the seal O.D. and the bore into which the seal is installed. Be sure the bore is free from nicks, scratches, and burrs.

C2.5 Do not cock the seal in the bore. The seal must be flush with the surface into which it is mounted.

C2.6 Check vent plug periodically to insure it has not become clogged.

C2.7 Shimming is required to properly set tapered roller bearings. When replacing bearings, shim to allow 0.001" - 0.002" total end play. Contact factory for complete instructions.

RECOMMENDED LUBRICANTS FOR WORM GEAR REDUCERS						
LUBRICANT CHARACTERISTIC						
AMBIENT TEMP. RANGE	-30 to 15° F (-34 to -9° C)	16° to 50° F (-9° Tto 10° C)	51° to 95° F (11° to 35° C) <i>(FACTORY FILLED)</i>	96° to 131° F (36° to 55° C)	-40° to 175° F (synthetic oils)	5° - 120° F Fluid Grease
SSU VISCOSITY at 104° F (40° C)	284 to 347	1919 to 2346	2837 to 3467	4171 to 5198	130 to 1112	...
AGMA LUBRICANT NO.	#6S	#7 Comp.	#8 Comp.	#8A Comp.	#5S	...
ISO GRADE	320	460	680	1000	...	SEE BELOW
LUBRICANT MANUFACTURERS						
CHEVRON	Tegra 220	Cylinder Oil W460	Cylinder Oil W680	Tegra 680
EXXON/ESSO	Teresstic SHP 220	Spartan EP 460	Spartan EP 680	Teresstic SHP 680
MOBIL	SHC630	600W Super or SHC 634	Extra Hecla Super Cyl.	Extra Hecla Super Cyl. Oil mineral or SHC 636	SHC 630	Mobilith SHC 007 (ISO 460)
SHELL	Omala RL 220	Valvata J-460	Valvata J-680	...	Omala RL 680	...
TEXACO	Pinnacle 220	Vanguard cyl. oil 460	Vanguard Cyl. oil 680	Pinnacle 680	...	Multifak HD00 (ISO 680)
FOOD GRADE		Chevron FM ISO-460	Chevron FM ISO-460			

TABLE C2.1

GEARBOX PARTS FOR E05 (917CDSF) TO E55 (943CDSF)

C3.1 See data sheet and/or assembly drawing to find the model number of gearbox supplied. The following drawing (Figure C3.1) shows standard parts for the E-Series gearboxes listed above. Refer to page C4 for models E6 through E9. Your model may vary slightly due to size and ratio. Bearing and seal part numbers are shown on Table C3.2. and C3.4. Seal number prefixes indicate seal manufacturers: 'CR' for Chicago Rawhide and 'JM' for John Manville.

C3.2 When requesting parts, pricing or other service assistance, have serial number and model number off mixer nameplate readily available. Before disassembling gearbox, contact factory for complete instructions on replacing shims, bearings and seals. Note: Drywell option not shown in figure C3.1.

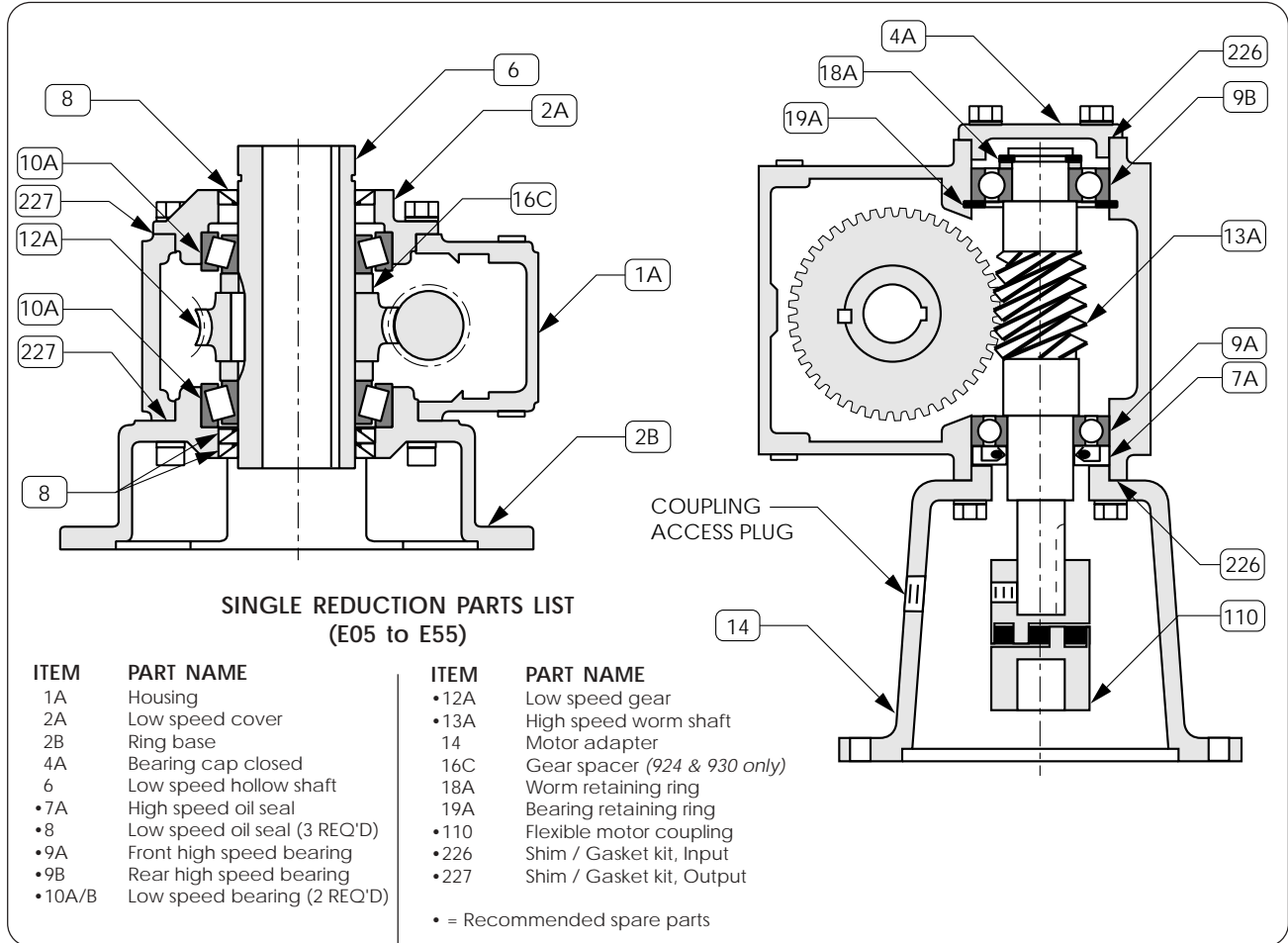

FIGURE C3.1

GEARBOX BEARINGS AND SEALS

Contact factory for all other parts.

GEARBOX	OIL SEALS		BEARINGS		
	HIGH SPEED Pos. No. 7A	LOW SPEED Pos. No. 8	FRONT H. S. Pos. No. 9A	REAR H.S. Pos. No. 9B	LOW SPEED Pos. No. 10A
E05	JM10335LPD	CR14705	6205	6205	JL69310/JL69349
E1	JM10335LPD	CR19762	6205	6304	JLM104910/LM104949
E2	CR13918	CR22354	6207	6207	382A/387
E3	CR13918	CR24898	6207	6207	394A/390A
E4	CR13986	CR26186	6208	6307	394A/399AS
E5	CR12458	CR28746	M88010/M88048	M88010/M88048	29620/29685
E55	CR12458	CR38692	M88610/M88649	M88610/M88649	52618/52400

TABLE C3.2

GEARBOX PARTS FOR E6 (A1002) TO E9 (A2002)

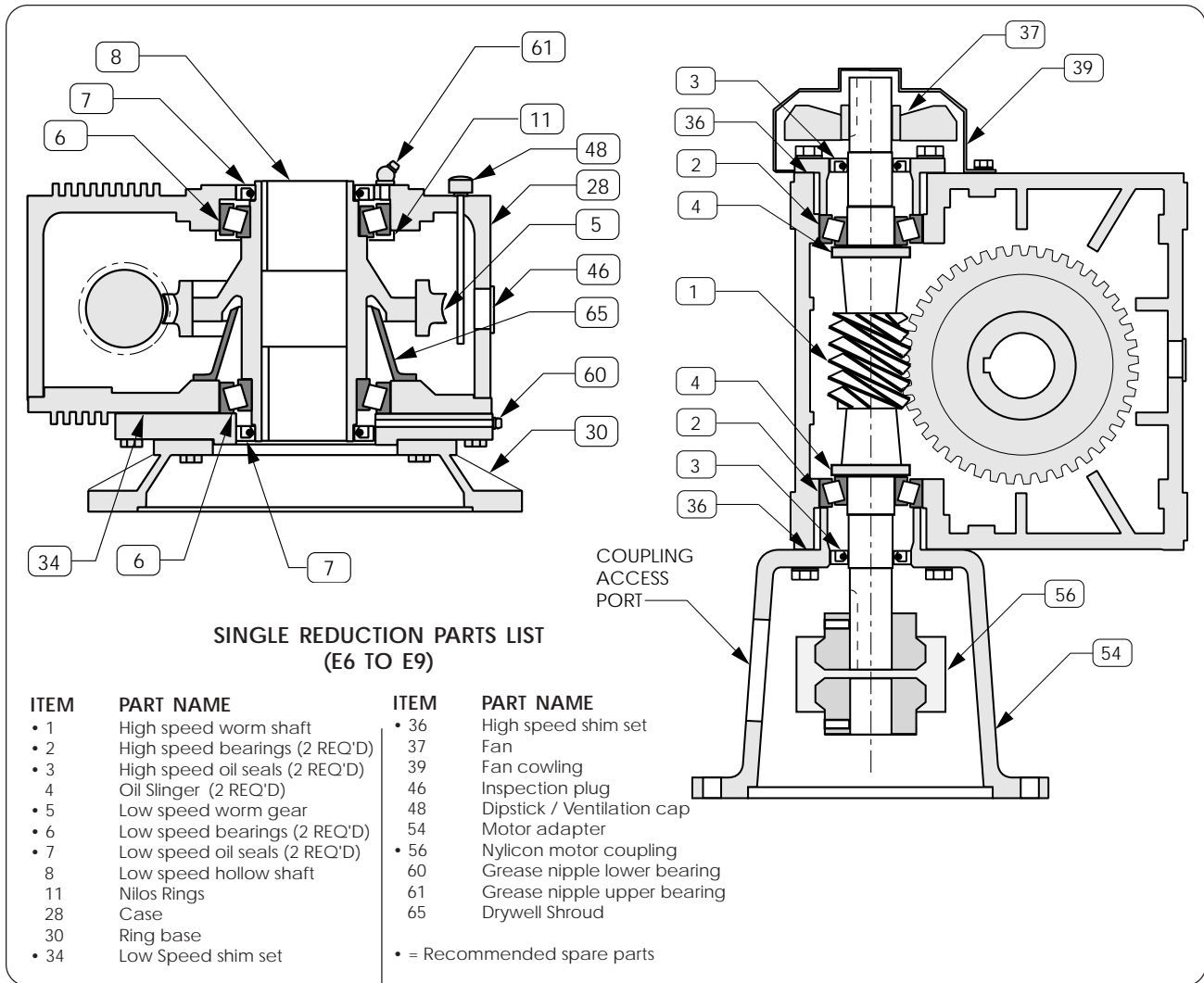

FIGURE C3.3

GEARBOX BEARINGS AND SEALS				
<i>Contact factory for all other parts.</i>				
GEARBOX	OIL SEALS		BEARINGS	
MODEL	HIGH SPEED Pos. No. 3	LOW SPEED Pos. No. 7	HIGH SPEED Pos. No. 2	LOW SPEED Pos. No. 6
E6	38 x 90 x 10	DPFA7810010	31308	32016X
E7	48 x 110 x 12	DPFA9512012	31310	32020X
E8	50 x 120 x 12	DPFA10513012	31311	32022X
E9	54 x 140 x 12	DPFA12515012	31313	32026X
Description	Double Lip Viton	Double Lip Nitril	Taper Roller	Taper Roller

TABLE C3.4

CAUTION: DO NOT DISASSEMBLE GEARBOX WITHOUT PRIOR AUTHORIZATION FROM SHARPE MIXERS OR WARRANTY WILL BE VOIDED. (DISREGARD WHEN MIXER IS OUT OF WARRANTY PERIOD.)

ALWAYS REFERENCE THE MIXER SERIAL NUMBER WHEN PLACING ORDER OR MAKING PARTS INQUIRY. THIS SERIAL NUMBER IS LOCATED ON THE SHARPE MIXER NAMEPLATE & IN THE FRONT COVER OF THE SERVICE MANUAL.