

101F, 101U



Declarations

Declaration of conformity 	When this pump unit is used as a stand alone pump it complies with: Machinery Directive 89/392/EEC EN60204-1, Low Voltage Directive 73/23/EEC EN61010-1, EMC Directive 89/336/EEC, EN50081-1/50082-1.
Declaration of Incorporation	When this pump unit is to be installed into a machine or is to be assembled with other machines for installations, it must not be put into service until the relevant machinery has been declared in conformity with the Machinery Directive 89/392/EEC EN60204-1.

Responsible person: Christopher Gadsden, Managing Director, Watson-Marlow Limited, Falmouth, Cornwall TR11 4RU, England. Telephone 01326 370370 Fax 01326 376009.



Two year warranty

Watson-Marlow Limited warrants, subject to the conditions below, through either Watson-Marlow Limited, its subsidiaries, or its authorised distributors, to repair or replace free of charge, including labour, any part of this product which fails within two years of delivery of the product to the end user. Such failure must have occurred because of defect in material or workmanship and not as a result of operation of the product other than in accordance with the instructions given in this manual.

Conditions of and specific exceptions to the above warranty are:

- Consumable items such as tubing, rollers and brushes are excluded.
- Products must be returned by pre-arrangement carriage paid to Watson-Marlow Limited, its subsidiaries, or its authorised distributor.
- All repairs or modifications must have been made by Watson-Marlow Limited, its subsidiaries, or its authorised distributors or with the express permission of Watson-Marlow Limited, its subsidiaries, or its authorised distributors.
- Products which have been abused, misused, or subjected to malicious or accidental damage or electrical surge are excluded.

Warranties purporting to be on behalf of Watson-Marlow Limited made by any person, including representatives of Watson-Marlow Limited, its subsidiaries, or its distributors, which do not accord with the terms of this warranty shall not be binding upon Watson-Marlow Limited unless expressly approved in writing by a Director or Manager of Watson-Marlow Limited.

Information for returning pumps

Equipment which has been contaminated with, or exposed to, body fluids, toxic chemicals or any other substance hazardous to health must be decontaminated before it is returned to Watson-Marlow or its distributor.

A certificate included at the rear of these operating instructions, or signed statement, must be attached to the outside of the shipping carton.

This certificate is required even if the pump is unused. If the pump has been used, the fluids that have been in contact with the pump and the cleaning procedure must be specified along with a statement that the equipment has been decontaminated.

Safety

In the interests of safety, this pump and the tubing selected should only be used by competent, suitably trained personnel after they have read and understood this manual, and considered any hazard involved.

Any person who is involved in the installation or maintenance of this equipment should be fully competent to carry out the work. In the UK this person should also be familiar with the Health and Safety at Work Act 1974.



There are dangerous voltages (at mains potential) inside the pump. If access is required, isolate the pump from the mains before removing the cover.

Recommended operating procedures

DO keep delivery and suction lines as short as possible using a minimum number of swept bends.

DO use suction and delivery pipelines with a bore equal to or larger than the bore of the tube fitted in the pumphead. When pumping **viscous** fluids, the losses caused by increased friction can be overcome by using pipe runs with a cross sectional area several times greater than the pumping element.

DO fit an extra length of pump tube in the system to enable tube transfer. This will extend tube life and minimise the downtime of the pumping circuit.

DO keep the track and rollers clean.

The self-priming nature of peristaltic pumps means valves are not required. Any valves fitted must cause no restriction to flow in the pumping circuit.

Tube selection The chemical compatibility list published in the Watson-Marlow catalogue is only a guide. If in doubt about the compatibility of a tube material with the duty fluid, request a tube sample card for immersion trials.

Installation

The 101F/R and 101U/R are suitable for single phase mains electricity supplies only.

- To ensure correct lubrication of the gearbox the pump should be run only while its feet are standing on a horizontal surface. The pump should be positioned to allow a free flow of air around it.

Set the voltage selector to either 120V for 100-120V 50/60Hz supplies or 240V for 220-240V 50/60Hz supplies.

A mains cable fitted with a moulded plug is supplied with the pump. The wires are colour coded in accordance with the following code:

- 220-240V: Live- Brown; Neutral - Blue; Earth - Green/Yellow.
- 100-120V: Live - Black; Neutral - White; Earth - Green.

Troubleshooting

Should the pump fail to operate, make the following checks to determine whether or not servicing is required.

- Check that the power switch is on.
- Check the mains supply is available at the pump.
- Check the voltage selector switch is in the correct position.
- Check the fuse in the mains socket.
- Check that the pump is not stalled by incorrect fitting of tubing.

101F/R operation

- Turn power switch to on (I) position to start pump.
- Turn power switch to off (O) position to stop pump.

101U/R Manual operation

- Set the front panel **Auto/Man** switch to **Man**.
- Turn power switch to on (I) position to start pump.
- Turn power switch to off (O) position to stop pump.
- Change pumping direction using the **CW/CCW** switch on the front panel, and set the pump speed using the digital potentiometer which is calibrated in percentage of maximum speed.
- To prime the pump at maximum speed press the **Max** key.

It is not necessary to disconnect the process signal from the rear panel 15-pin D connector or adjust the calibration potentiometers if returning to manual control after the pump has been in automatic operation.

101U/R Automatic operation

- Set the **Auto/Manual** switch to **Auto**.

For all auto and remote control operations, the drive is supplied with a 15 pin D connector.

	Never apply mains voltage across any pins on the 15D socket. Up to 30V may be applied across pins 2 and 10, but no voltage should be applied across other pins except where specified. Permanent damage not covered by warranty may result in both instances.
--	--

The pump is controllable by an analogue process signal of up to 30V or 32mA. The pump will provide an increasing flow rate for rising control signal (*non-inverted response*) or an increasing flow rate for falling control signal (*inverted response*).

- **Signal offset** is the process signal level which has to be reached in order for the pump rotor to start rotating.
- **Signal range** is the change in process signal level necessary to produce the required change in pump rotor speed.

For example, when using a 4mA to 20mA process signal:

Pump response	Signal offset	Signal range
Non-Inverted	4mA	16mA
Inverted	20mA	16mA

For voltage modes, a stable variable DC voltage source can be used in conjunction with a DC voltmeter, (maximum 30V DC). Polarity set for a non-inverted response. Reverse polarity for an inverted response.

Voltage signal

Input impedance 220 kohms

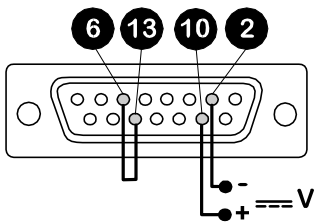

Response	Range V	Offset V	Pin 10	Pin 2
Non-inverted	5 to 30	0 to 30	-	+
Inverted	5 to 30	0 to 30	+	-

For current modes, the same DC source can be used in conjunction with a DC milliammeter, (maximum 32mA). Polarity set for a non-inverted response. Reverse polarity for an inverted response.

Current signal

Input impedance 250 ohms

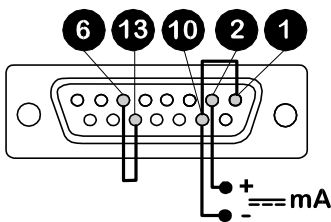

Response	Range mA	Offset mA	Pin 10	Pin 2	Link
Non-inverted	12 to 30	0 to 30	-	+	1&10
Inverted	12 to 30	0 to 30	+	-	1&10

101U/R Calibration procedure

- Turn the signal offset potentiometer (20 turn potentiometer) clockwise until the slider traverse limit is reached and is signified by a clicking noise. Now turn the potentiometer ten turns anticlockwise. Repeat for the signal range potentiometer. This ensures correct potentiometer set-up for calibration.
- Set the process signal offset.
- Turn the signal offset potentiometer clockwise to set the pump shaft speed to the desired minimum.
- Set the process signal at its upper range limit (not exceeding 30V or 32mA).
- Turn the signal range potentiometer (marked "Range" on back panel) clockwise to set the drive shaft speed to the desired maximum.

If the process signal or pump speed are set above their designated maximums the pump will be overloaded which is signified by the signal overload indicator illuminating. This is an indication of the limiting control and speed levels of the drive. Reset to operate within these levels.

- Repeat the procedure until pump response coincides exactly with the process signal.

Remote auto manual switch and TTL option

If the front panel switch is to be used for changing between "manual" and "auto", link pins 6 and 13 in the 15-pin Dee connector. If a remote switch is to be used, ensure that no link is present between pins 6 and 13, and wire the switch between pins 7 and 13 of the 15-pin Dee connector. Close switch for auto-control.

Alternatively, the remote auto-manual switch may be replaced by a 0/5V TTL compatible signal applied to pin 7 (reference pin 13). 0V = manual (Man), +5V = auto (Auto).

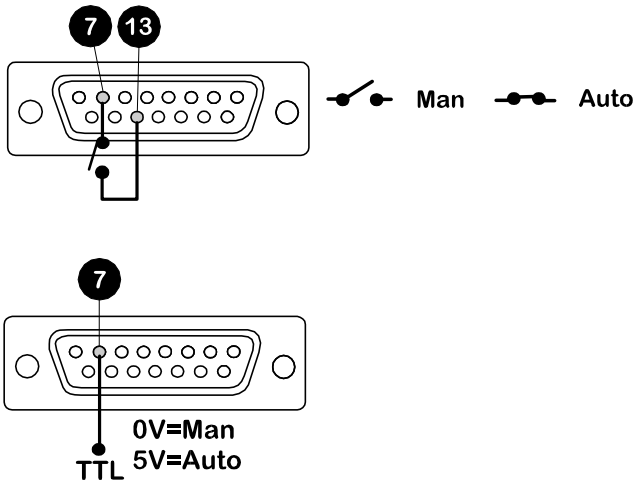

Remote operation

Stop/start

Connect remote switch between pins 8 and 13 of the 15 pin connector. A TTL compatible input (low 0V, High 5V) maybe applied to pin 8. Low input stops the pump, high input runs the pump. With no connection, the pump will default to running.

INVERT FAILSAFE
Please contact Watson-
Marlow Technical
Support

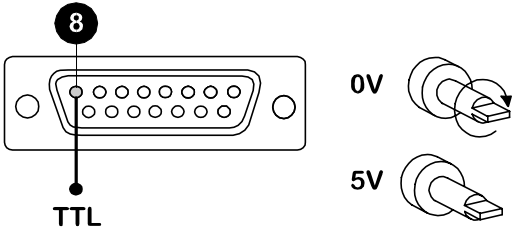
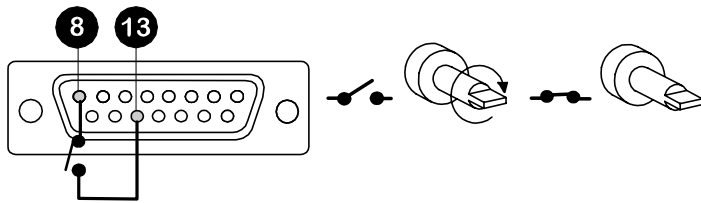

Tacho output

A signal is available at the Din socket which is approximately proportional to motor speed. Pin 11 is negative and pin 3 is positive. There is approximately 5V across the pins at maximum speed.

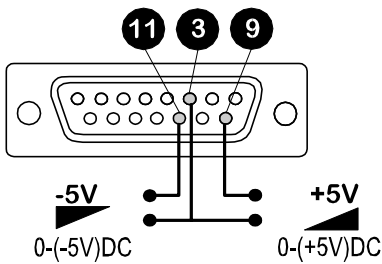

Remote potentiometer

A remote potentiometer with a maximum value of 5kohm should be wired as shown. When using a remote potentiometer, do not apply a voltage/current control input signal at the same time. The speed control signal will require calibration relative to the minimum and maximum settings of the potentiometer. Use the offset and range potentiometers as described under calibration.

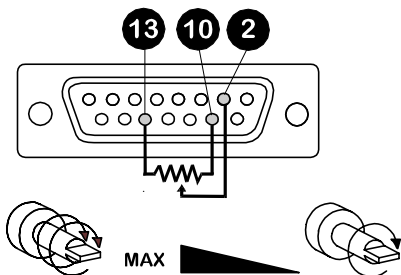

Direction

Connect remote switch between pins 5 and 13 and disable the front panel reversing control by linking pin 4 and 12 of the 15 pin D connector.

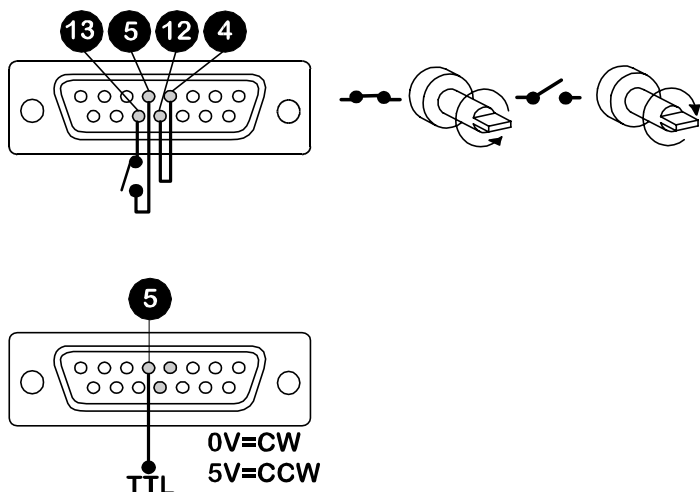

Care and maintenance

Scheduled maintenance of the 101U/R pump is not required. If harmful liquids are spilled on to the pump, the pumphead should be washed down thoroughly. The case and pumphead should be cleaned with detergent and water. Do not use strong solvents.

101F/R Specification

Nominal rotor speed	4rpm, 4.8rpm 20rpm, 24rpm
Volatge/frequency	100-120/220-240V 50/60Hz
Power consumption	25VA
Fuse rating	Type T (anti-surge) 0.08A
Operating temperature range	5 to 40C
Storage temperature range	-40C to 70C
Weight	1.7kg (4lb)
Noise	<70dBA at 1m
Standards	IEC 335-1, EN60529 (IP21) Machinery Directive 89/392/EEC EN60204- 1 Low Voltage Directive 73/23/EEC EN61010- 1 EMC Directive:89/336/EEC EN50081-1 / EN50082-1

101U/R Specification

Maximum rotor speed	2rpm, 32rpm
Volatge/frequency	100-120/220-240V 50/60Hz
Control ratio	25:1
Power consumption	25VA
Fuse rating	Type T (anti-surge) 0.1A
Operating temperature range	5 to 40C
Storage temperature range	-40C to 70C
Weight	2.2kg (4.8lb)
Noise	<70dBA at 1m
Standards	IEC 335-1, EN60529 (IP21) Machinery Directive 89/392/EEC EN60204- 1 Low Voltage Directive 73/23/EEC EN61010- 1 EMC Directive:89/336/EEC EN50081-1 / EN50082-1

Specific drive performance details such as loaded drive speed variation against mains supply voltage fluctuation and drive stability from a cold start to normal operating temperature are available on request. For further information please contact Watson-Marlow Technical Support Department.

102R Pumphead

The 102R is a twin roller pumphead for high precision flow rates. It is limited to the use of silicone tubing only.

Flow rates

Flow rates for the 101F/R and 101U/R were obtained using Watson-Marlow 1.6mm wall thickness Silicone tubing pumping water at 20C with negligible suction and delivery pressures (unless otherwise stated). Where an application is critical, the flow rate should be determined under operating conditions. The important factors are suction and delivery pressures, temperature and fluid viscosity.

Tube loading

- Isolate the drive from the mains supply.
- Fit one end of the tubing into one of the spring loaded clamps, and then whilst rotating the rotor by hand feed the tubing around the track (if resistance is felt to turning the rotor, turn the reversing switch to the other direction of rotation).
- Fit the other end of the tubing into the second spring loaded clamp ensuring that the tubing is not slack in the pumphead since this can reduce tube life.



101U/R drive spares

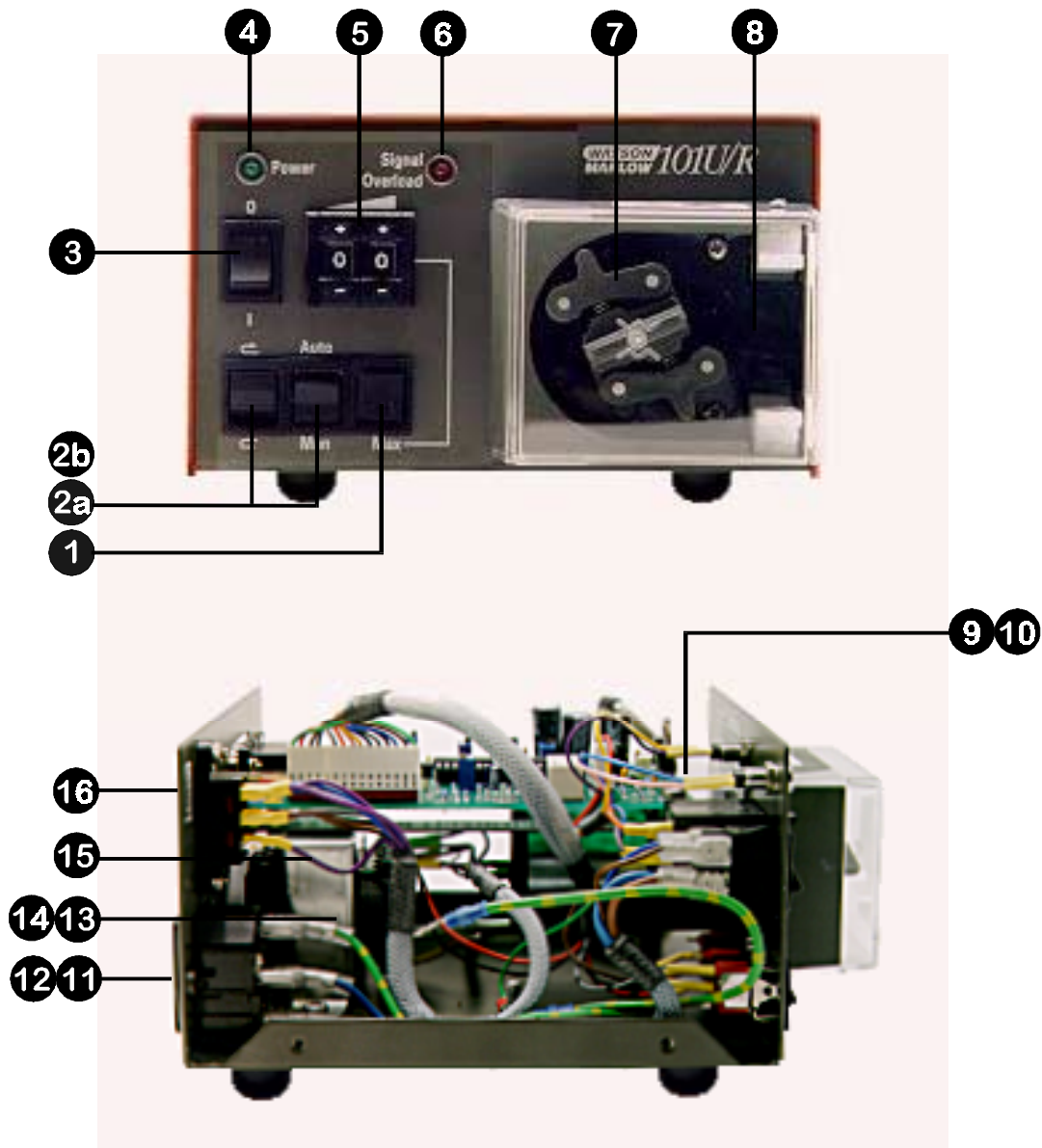

Item	Spare	Description
1	SW 0108	Max switch
2a	SW 0107	Auto switch
2b	SW 0107	Direction switch
3	SW 0112	Mains switch
4	SD 0002	Green LED
5	RV 0027	Digital potentiometer
6	SD 0031	Red LED
7	MNA0380A	102R rotor
8	MNA0359A	102R track
9	MG 0139	101U/R Motor/gearbox - 2rpm
10	MG 0140	101U/R Motor/gearbox - 32rpm
11	MNA0542A/ MNA0549A	Control PCB 32/2rpm
12	UP 0058	15 pin D connector
13	UP 0059	15 pin D connector socket
14	US 0045	Mains connector
15	FS 0017	Fuse 0.1 amp T type
16	TF0038	Transformer
	SW0086	Voltage selector switch

101F/R spares

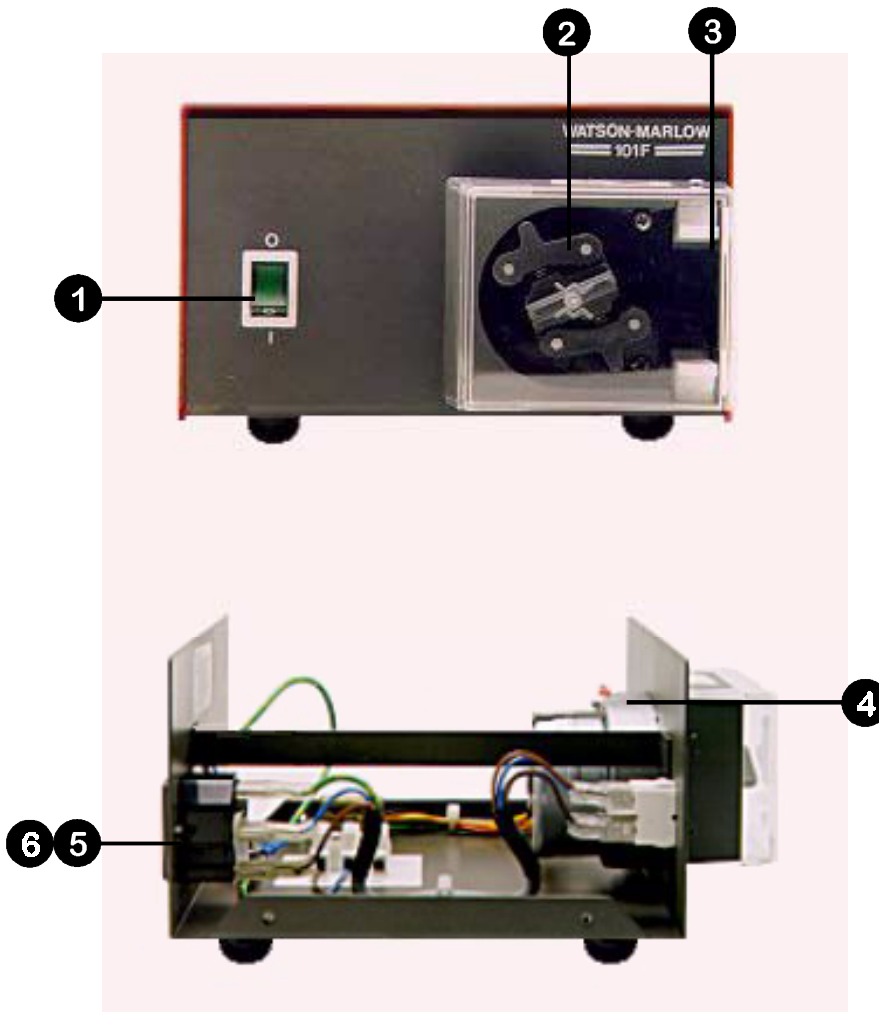

Item	Spare	Description
1	SW 0039 MNA0248A	On/off switch 240V On/off switch 120V
2	MNA 0381A	102R rotor
3	MNA0359A	102R track
4	MG 0130 MG 0129 MG 0136 MG 0137	4/4.8rpm, 100-120V 50/60Hz 4rpm, 200-250V 50Hz 20rpm, 200-220V 50Hz 20rpm, 230-250V 50Hz
5	US 0045	Mains connector
6	FS 0022	Fuse 0.08 amp T type

101U/R outline dimensions

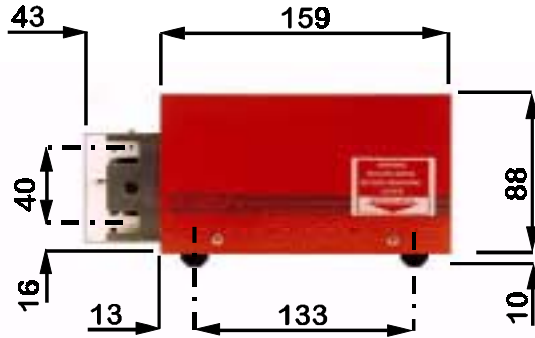

101F/R outline dimensions

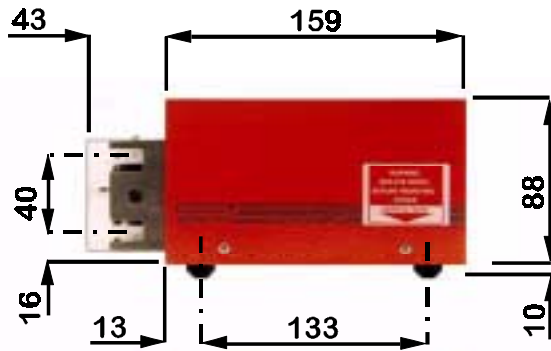

Technical Data

English	Tube number	Tube bore	rpm	Pressure (+)	Suction	Clockwise (rpm)	Anticlockwise (rpm)	Stop

102R (ml/min)

Flow rates						
	#	112	13	14	16	25
	mm	0.5	0.8	1.6	3.2	4.8
	"	1/50	1/32	1/16	1/8	3/16
	2	0.04	0.10	0.44	1.62	3.25
	32	0.69	1.61	7.00	26.0	53.0

102R

Product codes				
mm	"	#	Peroxide Silicone	Platinum Silicone
0.5	1/50	112	910.0005.016	913.0005.016
0.8	1/32	13	910.0008.016	913.0008.016
1.6	1/16	14	910.0016.016	913.0016.016
3.2	1/8	16	910.0032.016	913.0032.016
4.8	3/16	25	910.0048.016	913.0048.016

102R

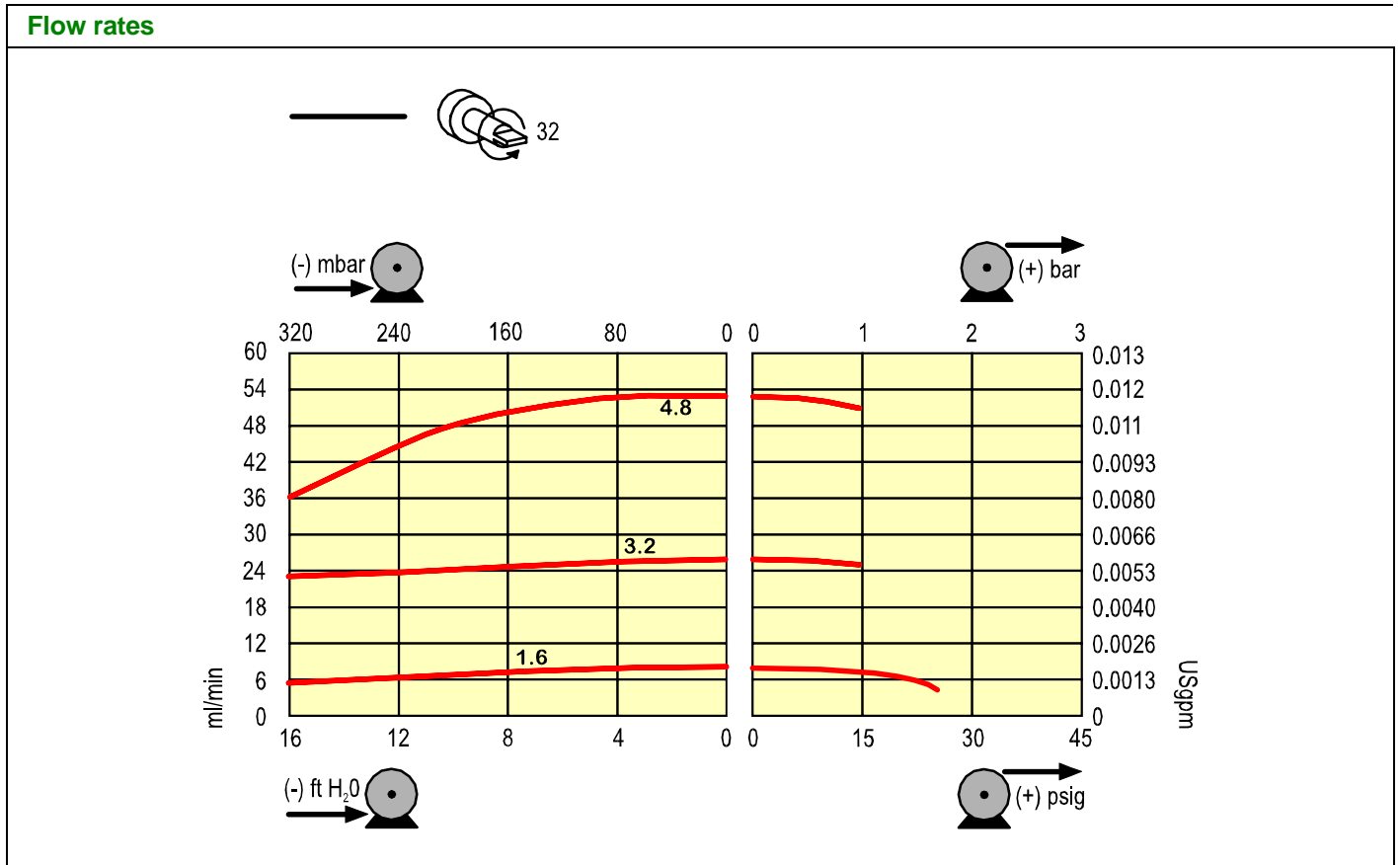

Watson-Marlow, Bioprene and Marprene are trademarks of **Watson-Marlow Limited**.

Tygon is a trademark of the **Norton** Company.

Warning, These products are not designed for use in, and should not be used for patient connected applications.

The information contained in this document is believed to be correct but Watson-Marlow Limited accepts no liability for any errors it contains, and reserves the right to alter specifications without notice.

Product use and decontamination declaration

In compliance with the **UK Health & Safety at Work Act** and the **Control of Substances Hazardous to Health Regulations** you, the user are required to declare the substances which have been in contact with the product(s) you are returning to Watson-Marlow or any of its subsidiaries or distributors. Failure to do so will cause delays in servicing the product. Therefore, **please complete this form** to ensure that we have the information **before** receipt of the product(s) being returned. **A FURTHER COPY MUST BE ATTACHED TO THE OUTSIDE OF THE PACKAGING CONTAINING THE PRODUCT(S).** You, the user, are responsible for cleaning and decontaminating the product(s) before returning them.

Please complete a separate Decontamination Certificate for each pump returned.

RGA

No:

1 Company

Address Postcode

Telephone Fax Number

2 Product

3.4 Cleaning fluid to be used if residue of chemical is found during servicing;

2.1 Serial Number

(a).....

2.2 Has the Product been used?

(b).....

YES		NO	
-----	--	----	--

(c).....

(d).....

If yes, please complete all the following Sections

If no, please complete Section 5 only

3 Details of substances pumped

4 I hereby confirm that the only substances(s) that the equipment specified has pumped or come into contact with are those named, that the information given is correct, and the carrier has been informed if the consignment is of a hazardous nature.

3.1 Chemical names:

(a)..... 5 Signed

(b)..... Name

(c)..... Position

(d)..... Date

3.2 Precautions to be taken in handling these substances:

(a).....

(b).....

(c).....

(d).....

Note: To assist us in our servicing please describe any fault condition you have witnessed.

3.3 Action to be taken in the event of human contact:

(a).....

(b).....

(c).....

(d).....