

HIGH CONSISTENCY ROTARY SCREEN THICKENER (HC-RST)

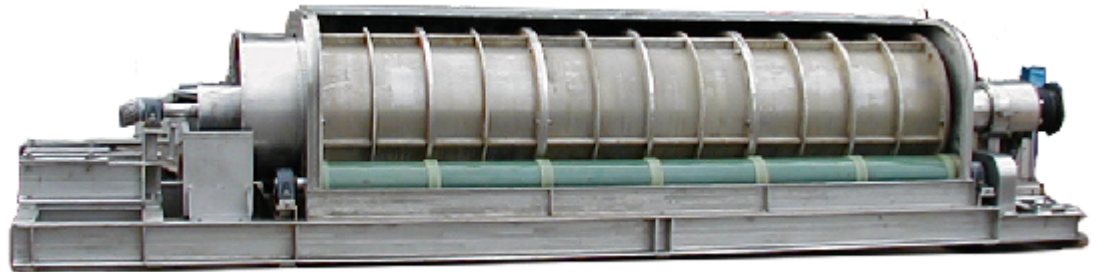
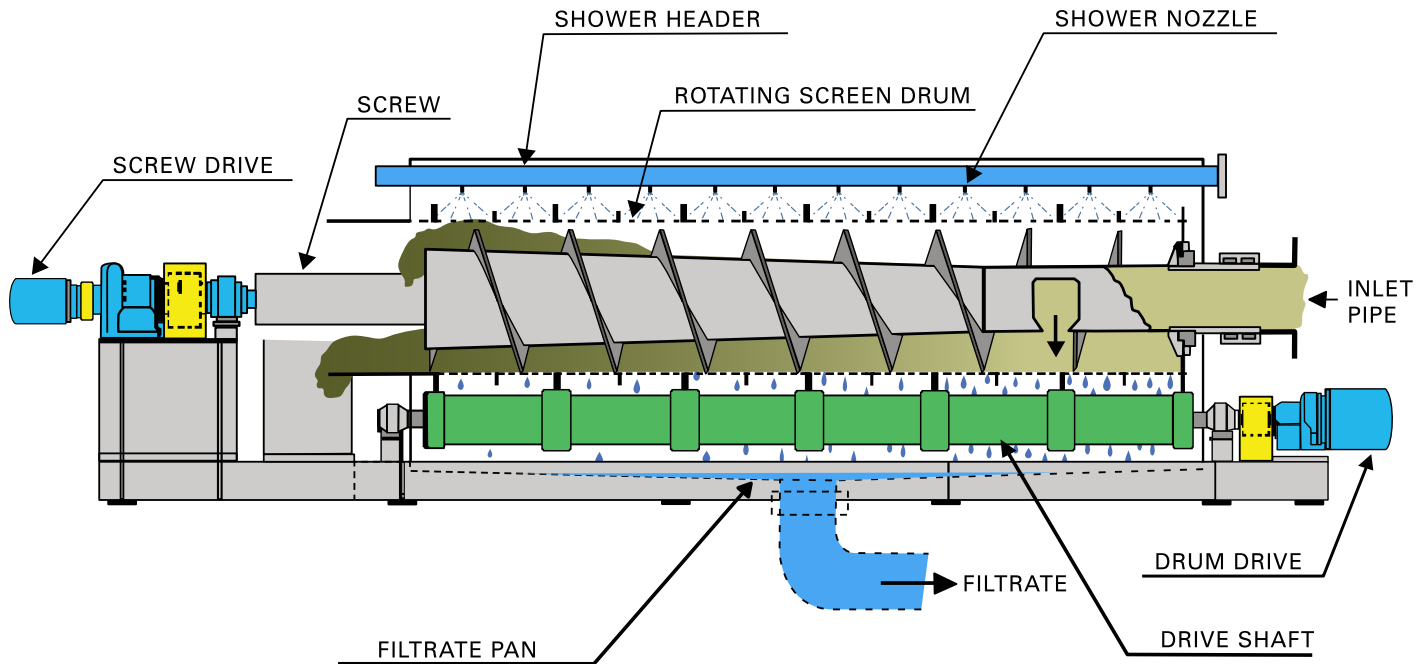

APPLICATIONS

- Prethickening prior to a screw press
- Thickening prior to an aerobic or anaerobic digester
- Thickening for reduced volume for transport
- Screening / Thickening of solids from a liquid/solids stream

FEATURES

- Increased Outlet Consistency & Capacity
- Independently Driven Counter Rotating Screw
- Stainless Steel Wetted parts
- Heavy Duty Construction
- Can Accept Inlet Consistencies <1%
- Outlet Consistency Typically Ranges 8–20%
- Patented Design
- Reduced Polymer Dosage
- Spray Shower Keep Screens Clean
- Multiple Sizes for Any Flow Rate
- Easy to Install and Operate
- Over 150 units in Operation



HC-RST plan and elevation view drawing

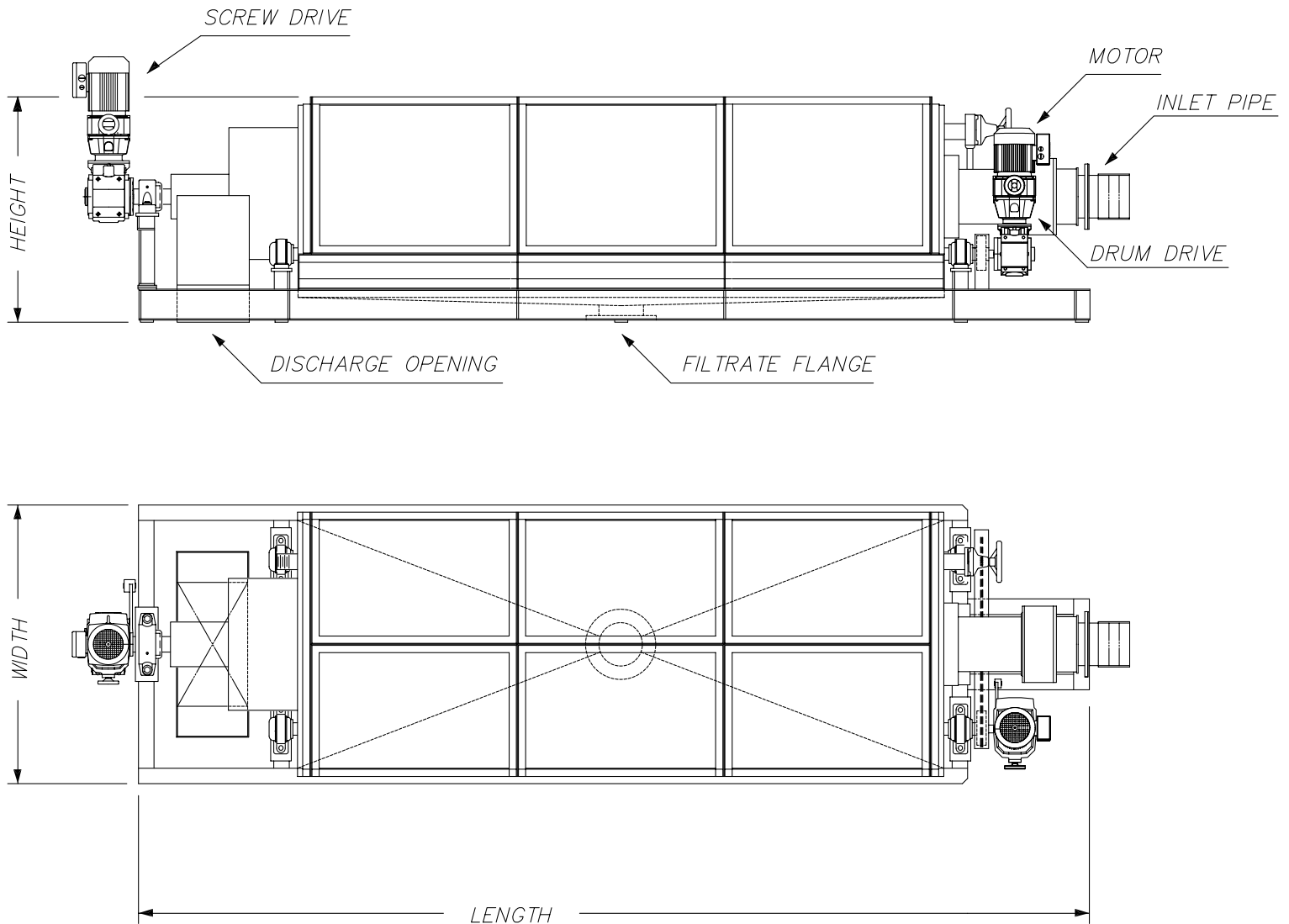

High Consistency Rotary Screen Thickeners

Model No.	Motor HP	Length	Height	Width	Weight	Shower gpm	Max. flow (gpm)
RST-HCS630x3000L	2 & 3	200"	43"	53"	7,000 lb.	15-20	300-350
RST-HCS775x3600L	3 & 5	235"	50"	58"	8,250 lb.	15-20	400-450
RST-HCW630x3000L	3 & 5	200"	43"	87"	9,700 lb.	30-40	600-700
RST-HCW775x3600L	5 & 10	235"	51"	93"	11,700 lb.	30-40	800-900

RST = rotary screen thickener

HC = high consistency model

S = single drum model

W = double drum model

First number = drum diameter in millimeters

Second number = drum length in millimeters

Shower water pressure = 30-40 psi recommended

Maximum flow rate capability varies depending on the specifics of a given application.



FKC Co., Ltd.
 2708 W. 18th Street
 Port Angeles, WA 98363
 (360) 452-9472
www.fkcscrewpress.com
mail@fkcscrewpress.com